

RUDOLF L. MÖSSBAUER

Recoilless nuclear resonance absorption of gamma radiation

Nobel Lecture, December 11, 1961

It is a high distinction to be permitted to address you on the subject of recoilless nuclear resonance absorption of gamma radiation. The methods used in this special branch of experimental physics have recently found acceptance in many areas of science. I take the liberty to confine myself essentially to the work which I was able to carry out in the years 1955 to 1958 at the Max Planck Institute in Heidelberg, and which finally led to establishment of the field of recoilless nuclear resonance absorption. Many investigators shared in the preparations of the basis for the research we are concerned with in this lecture. As early as the middle of the last century Stokes observed, in the case of fluorite, the phenomenon now known as fluorescence - namely, that solids, liquids, and gases under certain conditions partially absorb incident electromagnetic radiation which immediately is re-radiated. A special case is the so-called resonance fluorescence, a phenomenon in which the re-emitted and the incident radiation both are of the same wavelength. The resonance fluorescence of the yellow D lines of sodium in sodium vapour is a particularly notable and exhaustively studied example. In this optical type of resonance fluorescence, light sources are used in which the atoms undergo transitions from excited states to their ground states (Fig. 1). The light quanta emitted in these transitions ($A \rightarrow B$) are used to initiate the inverse process of resonance absorption in the atoms of an absorber which are identical with the radiating atoms. The atoms of the absorber undergo a transition here from the ground state (B) to the excited state (A), from which they again return to the ground state, after a certain time delay, by emission of fluorescent light.

As early as 1929, Kuhn¹ had expressed the opinion that the resonance absorption of gamma rays should constitute the nuclear physics analogue to this optical resonance fluorescence. Here, a radioactive source should replace the optical light source. The gamma rays emitted by this source should be able to initiate the inverse process of nuclear resonance absorption in an absorber composed of nuclei of the same type as those decaying in the source.

Again, the scheme of Fig. 1 would hold here, but the radiative transitions would now take place between nuclear states. Nevertheless, all attempts in the next two decades to find this nuclear resonance absorption proved fruitless. Before I can approach the subject of my talk, it is appropriate to consider the reasons why the discovery of nuclear resonance absorption was so long delayed.

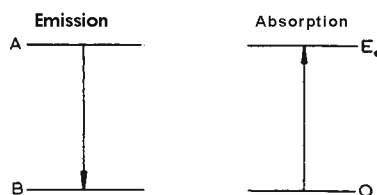

Fig. 1. Scheme of resonance absorption.

For simplicity, we shall first consider a nuclear transition of a free nucleus at rest. The gamma quantum emitted in the transition imparts a recoil momentum \vec{p} to the emitting nucleus and consequently a kinetic energy AE , which is given by

$$AE = \vec{p}^2/2M = E_0^2/2Mc^2 \quad (1)$$

where M is the mass of the nucleus and c is the velocity of light. The energy liberated in this nuclear transition is divided, in accordance with the law of conservation of momentum, the larger part being carried away by the emitted quantum, the other part going to the emitting nucleus in the form of recoil energy. This recoil-energy loss of the quantum has the consequence that the emission line does not appear at the position of the transition energy E_0 but is displaced to lower energy by an amount AE (Fig. 2). The absorption line, on the contrary, is displaced to a higher energy by the same amount AE , because in order for the process of resonance absorption to occur, a quantum must provide, in addition to the transition energy E_0 , the amount of energy AE which is taken up by the absorbing nucleus in the form of a recoil kinetic energy. Typical values for the line shifts AE lie in the range from 10^3 eV to 10^5 eV; they are therefore very small in comparison with the energies of the gamma quanta, which frequently are of the order of magnitude of millions of electron volts.

Since there is an uncertainty in the energies of the individual excited states

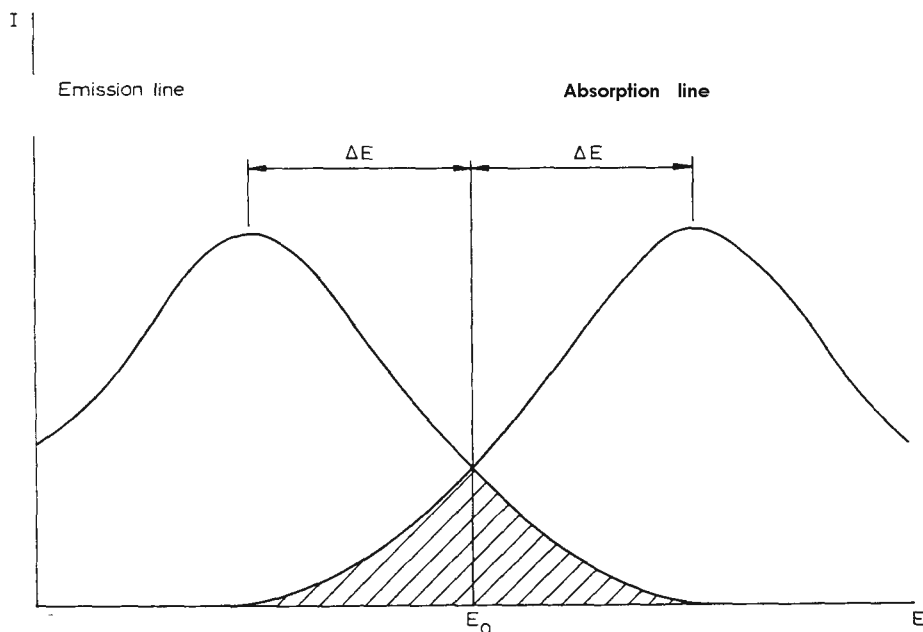

Fig. 2. Position and shape of the emission and absorption lines of a free nucleus (shown in the case of the 129-keV transition in ^{191}Ir for $T = 300^\circ\text{K}$).

of the nuclei, the lines associated with transitions between an excited state and the ground state have a certain minimum width. This so-called natural width Γ is, according to the Heisenberg uncertainty principle, connected with the lifetime τ of an excited nuclear state by the relation $\Gamma\tau = h$. The usual values for the lifetimes τ of the low-lying excited nuclear states lie in the range from 10^{-7} to 10^{-11} second, corresponding to an interval of 10^8 to 10^4 eV for the natural line widths appearing in ground-state transitions. Such extraordinarily sharp lines exhibiting the natural line width are normally not observed. Rather, a series of side effects always exist, which lead to considerable broadening such that the line widths ordinarily associated with low-energy gamma transitions exceed the natural minimum width by many orders of magnitude. The most important broadening mechanism is the thermal motion of the nuclei in the source and in the absorber; this leads to Doppler shifts in the energy of the gamma quanta and therefore produces corresponding line broadenings. Even a temperature drop to absolute zero does not extinguish this thermal broadening, since the existence of zero-point energy at absolute zero frequently produces, at least in solids, line

widths of the same order of magnitude as the ones existing at room temperature.

Usually the line shifts are large in comparison to the thermal line widths, and they are also always very large in comparison to the natural line widths associated with the low-energy nuclear transitions we are concerned with here. As a consequence, the energy of an emitted quantum is usually too small for the inverse process of resonance absorption to be carried out, or in other words, the probability of occurrence of nuclear resonance absorption is so small that the process escapes detection. Therefore the long and unsuccessful search for nuclear resonance absorption is to be blamed on the high recoil-energy losses of the gamma quanta.

On the other hand, entirely different conditions hold for optical resonance absorption. There, because of the much lower energies of the light quanta, the recoil-energy losses produced by light quanta are small in comparison with the line widths. Emission and absorption lines therefore overlap in an ideal manner, the resonance condition is satisfied, and the optical effect is, at least in principle, easily observable.

The unsatisfactory situation with respect to nuclear resonance absorption first changed in 1951, when Moon² succeeded in demonstrating the effect for the first time, by an ingenious experiment. The fundamental idea of his experiment was that of compensating for the recoil-energy losses of the gamma quanta: the radioactive source used in the experiment was moved at a suitably high velocity toward the absorber or scatterer. The displacement of the emission line toward higher energies achieved in this way through the Doppler effect produced a measurable nuclear fluorescence effect.

After the existence of nuclear resonance fluorescence had been experimentally proved, a number of methods were developed which made it possible to observe nuclear resonance absorption in various nuclei. In all these methods for achieving measurable nuclear resonance effects the recoil-energy loss associated with gamma emission or absorption was compensated for in one way or another by the Doppler effect.

At this point, let me speak of my esteemed teacher, Heinz Maier-Leibnitz, who in 1953 directed my attention to this newly advancing field of nuclear resonance fluorescence, and who stimulated me to turn to this area of research. He was, also, the one who made it possible for me to conduct my research throughout the years 1955 to 1958 at the Heidelberg Max Planck Institute, in an undisturbed and fruitful atmosphere - research which finally led to the discovery of recoilless nuclear resonance absorption. I want to express

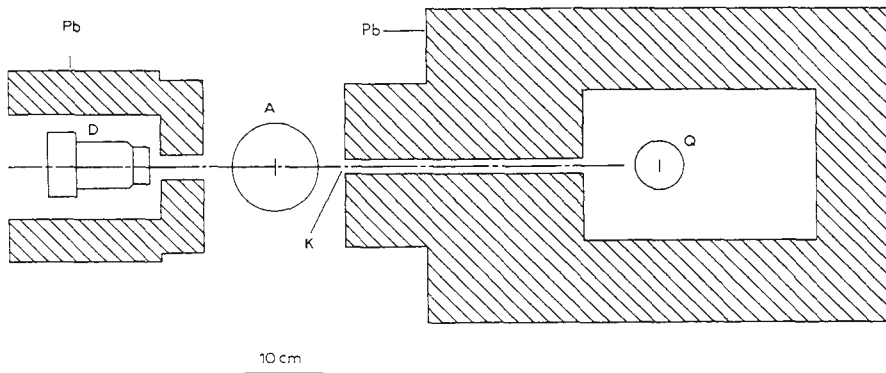

Fig. 3. Experimental arrangement. *A*, absorber-cryostat; *Q*, cryostat with source; *D*, scintillation detector; *K*, lead collimator.

my warmest thanks to my esteemed teacher for his efforts on my behalf.

The method which I shall now proceed to discuss differs fundamentally from the methods described above in that it attacks the problem of recoil-energy loss at its root in a manner which, in general, insures the complete elimination of this energy loss. The basic feature of this method is that the nuclei in the source and absorber are bound in crystals. The experiments described in the following paragraphs exclusively employed radioactive sources which emitted the 129-keV gamma line leading to the ground state in ^{191}Ir .

The first experiment³ aimed at measuring the lifetime of the 129-keV state in ^{191}Ir by utilizing methods of nuclear resonance absorption known at that time. The experimental set-up used for this purpose is shown schematically in Fig. 3. A method first employed by Malmfors⁴ appeared to be especially suitable for the planned measurement. In this method, a broadening of the emission or absorption line, leading to a corresponding increase in the degree of overlap of the two lines, is achieved by increasing the temperature. If the relative shift of the emission and the absorption lines resulting from the recoil-energy losses is only of the order of magnitude of the line widths, a temperature increase leads, under favourable conditions, to a measurable nuclear absorption effect. In the case of the 129-keV transition in ^{191}Ir , there is considerable overlap of the two lines even at room temperature as a consequence of the small energies of the quanta and the small line shifts resulting therefrom (see Fig. 2). In this case, not only an increase but also a decrease in temperature can result in a measurable change in the nuclear absorption.

My decision between these two possibilities was made in favour of a temperature decrease. It was motivated essentially by the consideration that at low temperature, effects of chemical binding would be more likely than at elevated temperatures. This hypothesis was vindicated in an unexpected way during the course of the experiments. The simultaneous cooling of the source and the absorber with liquid air led to inexplicable results, for which I first blamed effects associated in some way with the cooling of the absorber. In order to eliminate these unwanted side effects, I finally left the absorber at room temperature and cooled only the source. In very tedious experiments, which demanded extremely stable apparatus, a small decrease in the absorption with respect to the value at room temperature was in fact obtained - a result consistent with my expectations. The evaluation of these measurements finally led to the determination of the lifetime sought for.

In a second series of experiments I attempted to explain the side effects which had appeared in the simultaneous cooling of the source and the absorber during the earlier experiments. The result of this attempt was striking :

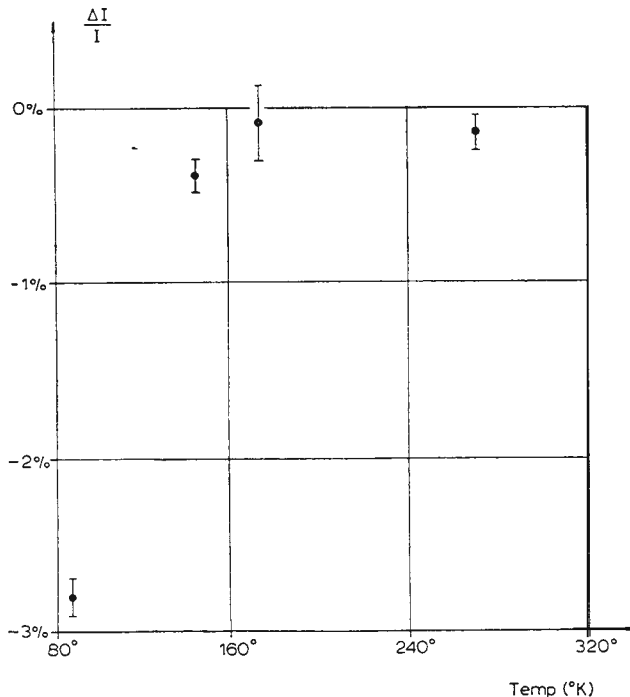

Fig. 4. Temperature dependence of the absorption. Relative intensity change $\Delta I/I$ in comparison with that of a non-resonant absorber.

instead of the decrease expected, a strong increase in the absorption clearly manifested itself when the absorber was cooled. This result was in complete contradiction to the theoretical expectation. The observed temperature dependence of this absorption is shown in Fig. 4.

In considering the possible sources of the anomalous resonance effect, I now began to subject the hypothesis of the existing theory to a critical examination.

The views originally held as to the shape and energy of the emission and absorption lines were based on the assumption that the emitting and absorbing nuclei can be treated as free particles. It was therefore natural to modify this assumption, taking into account the fact that source and absorber were each used in crystalline form. Therefore, I first attempted to explain the observed anomalous resonance absorption by assuming that the recoil momentum was not transferred to the single nucleus. It should rather be transferred to an assembly of nuclei or atoms which include nearest or next-nearest neighbours surrounding the nucleus under consideration. After the failure of this and other attempted explanations, based on a purely classical point of view, I turned my attention to a quantum-mechanical treatment of the problem.

Let me here introduce some concepts from crystal physics, by means of which I will develop the reasoning that finally led to a solution of the problem. All the internal motions of the particles forming the crystal lattice can be described in terms of a superposition of a large number of characteristic vibrations whose distribution is called the frequency spectrum of the crystal. The nature of the binding of the particles forming the crystal determines the structure of the lattice vibrational spectrum, this spectrum often being very complicated. Nevertheless, the substitution, for the true vibrational spectrum of the lattice, of a much simpler frequency distribution often suffices for qualitative considerations.

This first, still purely classical picture of the internal motions in a crystal corresponds, in the quantum-mechanical description, to a system of uncoupled harmonic oscillators with quantized energy states. While the vibrational spectrum describes only the distribution of the fundamental frequencies of these oscillators, the temperature determines the so-called occupation numbers of these crystal oscillators; these occupation numbers simply tell which of the possible energy states the particular oscillators occupy.

The recoil energy appearing in the emission or absorption of a quantum by a nucleus bound in a crystal is taken up by the crystal partly in the form

of translational energy and partly in the form of internal energy. The resultant increase in translational energy is always negligible because of the enormous mass of the crystal as a whole in comparison to the mass of a single nucleus. An increase in the internal energy leads to changes in the occupation numbers of the individual crystal oscillators. Because of the quantization of the oscillator energies, the crystal can absorb the recoil energy only in discrete amounts. The nuclear transitions of the bound nuclei are normally accompanied by simultaneous transitions of the crystal oscillators. Thus, for example, a gamma quantum can be emitted and simultaneously one of the crystal oscillators can undergo a transition to a neighbouring energy state. Likewise, a gamma emission process can be accompanied by simultaneous transitions of two crystal oscillators, and so forth. As a consequence of the quantization of the oscillators, there also exists in principle the possibility that the gamma transition takes place with none of the crystal oscillators changing their states.

The problem now was to compute the probabilities of the various processes. Significant was the calculation of the probability of nuclear transitions leaving the lattice state unchanged - that is, transitions in which no recoil energy is transferred to the lattice in the form of internal energy. Similar problems had already been solved much earlier. The coherent scattering of X-rays from crystals had been known for decades; in that case a momentum transfer to the reflecting lattice takes place without simultaneous transfer of internal energy to the crystal. And for a long time the analogous problem of the elastic scattering of slow neutrons from crystals had been thoroughly studied, both experimentally and theoretically. Lamb⁵ had, as early as 1939, developed a theory for the resonance capture of slow neutrons in crystals. This theoretical work was somewhat premature, inasmuch as Lamb assumed considerably smaller values for the widths of the neutron lines than were observed in later experiments. For this reason, this extraordinarily beautiful work was of no practical significance in the area of application originally intended. It remained only to apply this Lamb's theory to the analogous problem of the resonance absorption of gamma radiation. This indeed enabled me to show that under the conditions chosen in the experiments described above there exists a high probability of nuclear transitions with no simultaneous change of the lattice state. Since these nuclear transitions are not associated with any energy losses caused by recoil phenomena, I shall in the following discussion characterize these particular transitions as «recoilless» transitions, and the lines associated with such transitions, as «recoilless»

lines». In such a recoilless emission process, the entire excitation energy is therefore transferred to the emitted quantum, and the corresponding situation holds for the recoilless absorption. Here the notation «recoilless» relates only to recoil energy transferred in a nuclear transition, and not to the transferred momentum. The value of this transferred momentum is determined by the energy of the gamma quantum and is essentially a constant, independent of any change in the internal state of motion of the crystal. This momentum is, therefore, transferred to the lattice in all emission or absorption processes, even in the recoilless processes. It is always taken up by the crystal as a whole, and therefore the corresponding translational velocity is negligibly small.

What are the conditions under which the recoilless nuclear resonance absorption can be observed? In answering this question, I wish to develop here, without presenting the mathematical formulation of the theory, a detailed picture of the processes which take place in radiative transitions in nuclei bound in crystals. The recoil-energy loss that occurs in a nuclear transition of a free nucleus is given by Eq. (1). It can be shown that in a transition of a nucleus bound in a crystal, Eq. (1) is no longer valid for the individual process but holds in the means over many processes; that is, instead of Eq. (1), we now have

$$\overline{\Delta E} = E_0^2/2Mc^2 \quad (2)$$

Let us now consider a very simple model, in which we describe the vibrational state of the crystal by a single frequency ω , the so-called Einstein frequency. It is instructive to consider the two limiting cases, in which the mean recoil energy is either large or small in comparison to the transition energy of the Einstein oscillator:

$$\begin{aligned} \overline{\Delta E} &> \hbar\omega & (\text{case 1}) \\ \overline{\Delta E} &< \hbar\omega & (\text{case 2}) \end{aligned}$$

In case 1, many oscillator transitions are required to take up the energy contribution $\overline{\Delta E}$ in the lattice. The nuclear processes will therefore in general be accompanied by simultaneous transitions of many oscillators. The probability of a nuclear transition taking place without any oscillator transition - that is, the probability of a recoilless process - is correspondingly small. The situation is entirely different in case 2. Here it is immediately evident that

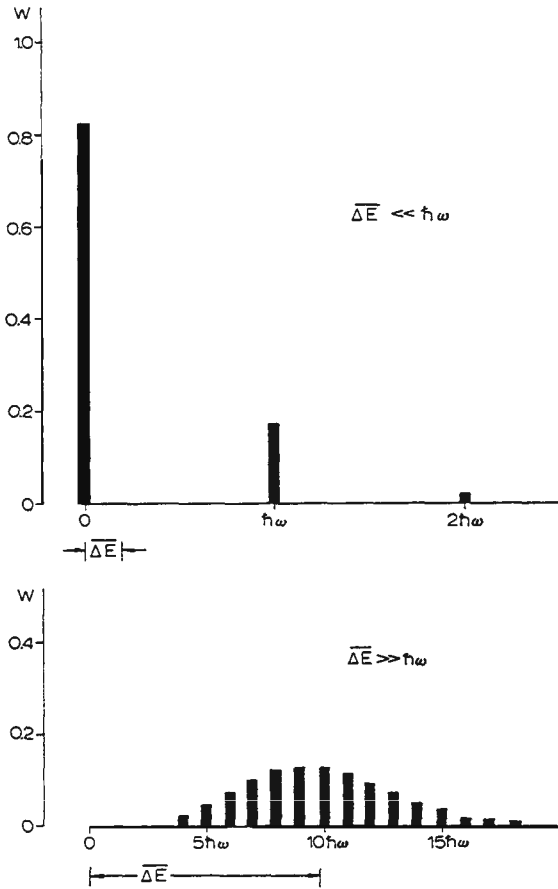

Fig. 5. Relative probability for a gamma transition associated with simultaneous transitions of 0, 1, 2, . . . n crystal oscillators, for two different values of $\overline{\Delta E}$ for the temperature $T = 0^\circ\text{K}$.

a nuclear transition which is accompanied by an oscillator transition occurs relatively seldom, leading under these circumstances to a high probability for recoilless processes. The probabilities, under these conditions, for the occurrence of gamma emission processes accompanied by 0, 1, 2, . . . n oscillator transitions are shown in Fig. 5 for these two cases.

For qualitative considerations this simple picture can well be applied to the case of the real crystal. The frequency spectrum of the real crystal exhibits an increasingly high oscillator density at high frequencies. It is sufficient, for this simplified consideration, to replace the Einstein frequency by the upper frequency of the vibrational spectrum of the real crystal. This

limiting frequency ω_g is related, approximately, to the characteristic temperature θ of the crystal by the equation $\hbar\omega_g = k\theta$.

The essential condition for a high probability of recoilless nuclear transitions now has the form

$$E_0^2/2Mc^2 < k\theta \quad (3)$$

The condition given here is quite restrictive because it limits the observation of recoilless resonance absorption to nuclear transitions of relatively low energy; the upper limit lies at about 150 keV.

If $\Delta E = E_0^2/2Mc^2$ is small in comparison to the upper energy limit of the frequency spectrum, the percentage of recoilless processes that occur is high even at room temperature. However, if ΔE is about equal to the upper energy limit of the frequency spectrum, then the probability of transitions of the crystal oscillators must be correspondingly reduced by the use of low temperatures in order to arrive at measurable effects.

After the appearance of the observed strong resonance absorption in ^{191}Ir had been traced back to the phenomenon of recoilless nuclear resonance absorption, the next step was to compute the probability of the effect in a general form. This probability, also known as the Debye-Waller factor, in analogy with the terminology used in X-ray scattering, is, as I have already pointed out, strongly dependent on the temperature and the energy of the nuclear transition. This dependence is illustrated in Fig. 6 by two examples.

The shape and location of the emission and absorption lines, as shown in Fig. 2 for the case of a free nucleus, are modified considerably by the influence of the chemical binding. While the centres of the lines as given by Eq. (2) are retained, each of them shows a complicated structure which reflects different single and multiple oscillator transitions, hence the notion « line » is applied here in a more generalized sense.

The most interesting prediction of the theory is the appearance of a strong line with the natural line width appearing in the structure of both « lines » at the position of the transition energy E_0 . This line represents the recoilless processes. The strong prominence of these lines with the natural line width within the total line structure is not so surprising when one considers that all the recoilless processes in the emission and absorption spectra appear within an energy range of the order of magnitude of the natural line width. The gamma transitions associated with the oscillator transitions appear, on the other hand, in an energy range of the order of magnitude of the Debye

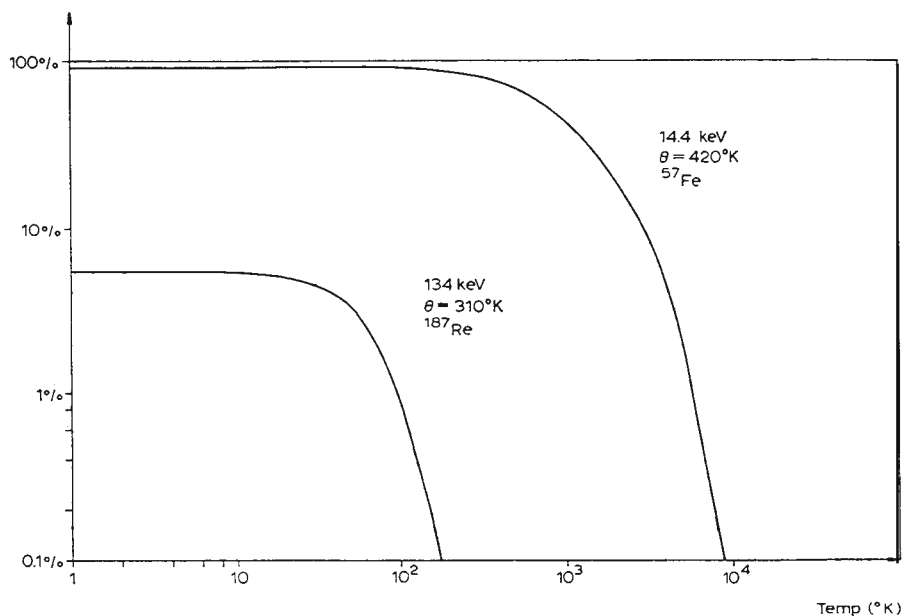

Fig. 6. Fractions of recoil-free nuclear transitions (Debye-Waller factors) in ^{57}Fe and ^{187}Re , shown as functions of the temperature.

temperature of the crystal; this energy range is always broader than the natural line width by many orders of magnitude.

All these considerations provided a very plausible explanation of the origin of the observed resonance absorption in ^{191}Ir at low temperatures. The agreement between the experimentally observed temperature dependence of the absorption (Fig. 4) and the theoretically computed dependence was satisfactory when one considered that in the first calculation the Debye approximation was used for the frequency spectrum because the actual frequency spectra of the crystals used were not known. Notwithstanding this qualitative agreement between experiment and theory, the situation still appeared to be somewhat unsatisfactory. The theory predicted that under the prescribed conditions lines of natural width should appear in the structure of the emission and absorption lines at the value of the transition energy E_0 .

While the assumption of the existence of these lines made it possible to explain the experiments thus far carried out, the keystone was evidently still missing - namely, direct experimental proof of the existence of these lines and, especially, a demonstration that their widths were indeed the natural

line widths. It was necessary to find a detector which had the necessary energy resolution to measure the profiles of these extremely sharp lines. The use of conventional detectors was excluded from the start. For example, the scintillation detectors frequently used for gamma-ray measurements in the relevant energy region have resolutions of the order of magnitude of 10^4 eV, while the natural line widths of the observed lines were only about 10^6 eV. The possibility of using the atomic nuclei themselves as detectors was suggested as a way out of this situation. As was shown above, an essential prediction of the theory was that the recoilless lines in both the emission and the absorption spectra should appear at the same position - that is, at the value of the transition energy.

Both lines would, therefore, overlap completely, this being the reason for the strong absorption effect. If one could succeed in partially removing the perfect overlap by a relative displacement of the lines, the absorption effect of the recoilless lines should disappear correspondingly.

In the experiment carried out to test the validity of this prediction, the idea was to accomplish the relative shift of the lines by means of the Doppler effect, so that a relative velocity would be imparted to the nuclei of the source with respect to the nuclei of the absorber. Here we had a sort of reversal of the experiment carried out by Moon. Whereas in that experiment the resonance condition destroyed by the recoil-energy losses was regained

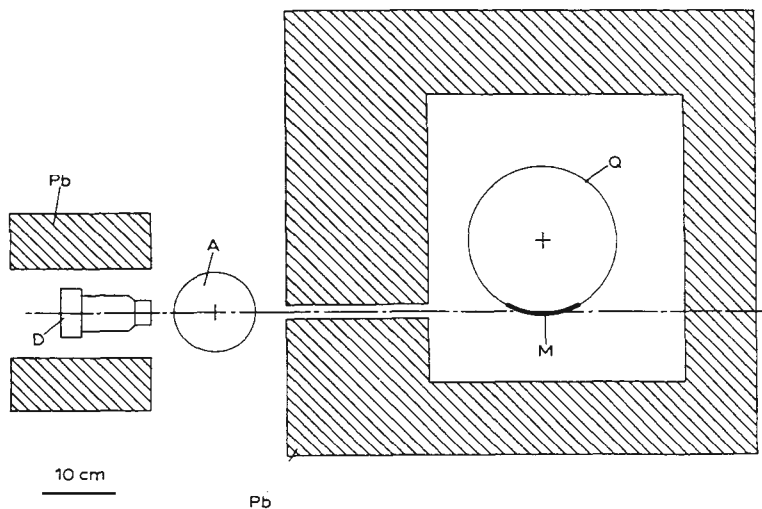

Fig. 7. Experimental arrangement. A, absorber-cryostat; Q, rotating cryostat with source; D, scintillation detector.

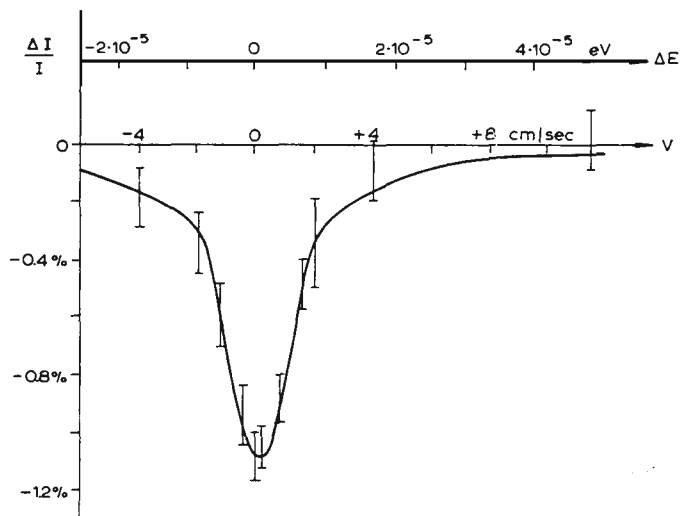

Fig. 8. Relative intensity ratio $\Delta I/I$ of gamma radiation measured behind the resonant iridium absorber, in comparison with intensities measured behind a nonresonant absorber.

by the application of an appropriate relative velocity, here the resonance condition fulfilled in the experiment was to be destroyed through the application of a relative velocity. And yet there was an essential difference between this and Moon's experiment. There, the width of the lines that were displaced relative to one another was determined by the thermal motion of the nuclei in the source and absorber; here, the line widths were sharper by four orders of magnitude. This made it possible to shift them by applying velocities smaller by four orders of magnitude. The indicated velocities were in the region of centimeters per second.

Fig. 7 shows the experimental arrangement⁶. For simplicity, I decided to move the source by means of a turn-table. Only the part of the rotational motion marked by the heavy line in Fig. 7 was used for the measurement - namely, that part in which the source was moving relative to the absorber with approximately constant velocity. The intensity at the detector was measured as a function of the relative velocity between the source and the absorber. Since the preparation of the conical-gear assembly necessary for adjusting the various velocities caused a disagreeable delay in this experiment which was so exciting for me, I took advantage of the existence in Germany of a highly developed industry for the production of mechanical toys. A

day spent in the Heidelberg toy shops contributed materially to the acceleration of the work.

Fig. 8 shows the result of this experiment, a result which was just what had been expected. As the figure demonstrates, a maximum resonance absorption was actually present at zero relative velocity as a result of the complete superposition of the recoilless emission and absorption lines; therefore, minimal radiation intensity passing through the absorber was observed in the detector. With increasing relative velocity the emission line was shifted to higher or lower energies, the resonance absorption decreased, and the observed intensity correspondingly increased. The necessary relative velocities were manifestly only of the order of centimeters per second. Since the experiment consisted essentially of producing a shift of an emission line of width T relative to an absorption line of width T , the observed line possessed a width which, with a small correction, was equal to $2 T$. It was especially satisfying that the line width thus obtained agreed with the width determined in the first experiment³ under much more difficult conditions. While absorption effects of the order of 1 per cent were observed in the second experiment, an effect of the order of a hundredth of 1 per cent had been achieved in the earlier work. Thus, direct proof of the existence of recoilless absorption was achieved.

The significance of the new method was immediately apparent, although not all of its consequences were immediately realized. With 4.6×10^6 eV the line width observed in the 129 keV gamma transition of ¹⁹¹Ir was already smaller than the usual thermal line widths by many orders of magnitude. Let us define the energy resolving power $E/\delta E$ by the ratio of the energy E_0 of the nuclear transition and the natural width T of the line; that is, $E/\delta E = E_0/T$. Then we obtain in the present case $E/\delta E = 2.8 \times 10^{10}$. The actual energy resolution achieved was already much greater in this experiment, since energy shifts amounting to a small fraction of the natural line width were actually observed. Since then, it has become possible, by utilizing other nuclear isotopes, to improve the obtainable energy resolution once more by several orders of magnitude. It is this property of the recoilless nuclear resonance absorption - namely, that it is possible by this means to measure extraordinarily small energy differences between two systems - which gave the method its significance and opened up a broad field of possible applications.

Thus, the extraordinary sharpness of the recoilless gamma lines brought direct investigation of the hyperfine structure of nuclear transitions within

the range of possibility. As a rule, atomic nuclei possess electric and magnetic moments in their various excited states. The interaction of these moments with internal or external fields leads to a splitting of nuclear levels into a number of states that are very close to one another. This hyperfine structure normally remains hidden in gamma lines, since the thermal width of a gamma line is always very large in comparison to the spacing of the hyperfine levels of the nuclear state. When the distances between the individual hyperfine components are larger than the natural widths of the gamma lines, as is frequently the case, and when the conditions necessary for the observation of recoilless absorption are fulfilled, this method makes possible direct measurements of the hyperfine structure of both participating nuclear states. Instead of a single line with the natural line width, a whole set of lines now appears in the emission spectrum, corresponding to recoilless transitions between the hyperfine levels of the nuclear excited and ground states. The same situation holds for the absorption spectrum. Studies of this type yield predictions on the magnetic dipole and electric quadrupole moments of the nuclear states involved, as well as predictions on the magnetic fields and gradients of the electric field prevailing at the site of the nucleus. The special promise of such measurements lies primarily in the possibility of obtaining information on the hyperfine splitting of excited nuclear states. In fact, several moments of excited nuclear states have been determined in this way in various laboratories. However, in our laboratory and in laboratories of many others now working in this region, this method is used mainly for studying the internal fields existing at the site of the nucleus; such studies have already led to a series of interesting results.

In addition to measurement of the fields located in crystals at nuclear sites and to measurement of the moments of excited nuclear states, studies of a number of important effects have been made during the past two years in a large number of laboratories. The observation of these effects was made possible by means of even sharper nuclear transitions, especially that of the 14.4-keV transition in ^{57}Fe .

Particular mention should be made here of the beautiful measurements of the energy shift of radiation quanta in the gravitational field of the earth⁷, the observation of the second-order Doppler effect, and the measurements of the isomeric shift. However, discussion of these and of a whole series of other effects which have been studied by means of the method of recoilless nuclear resonance lies outside the framework of this address.

The interpretation of the formalism which underlies the quantitative de-

scription of recoilless nuclear resonance absorption has led to extremely active discussions. The question particularly raised has been whether the effect can be explained classically and, in this connection, whether the momentum transfer takes place as a continuous process during the lifetime τ of the excited nuclear state or as a spontaneous process in the sense of quantum electrodynamics. The question raised here is closely connected with the problems encountered in the dualistic description of radiation as a wave process or as a stream of free particles. Notwithstanding the fact that many details of the recoilless resonance absorption can be described by classical models, I should characterize this effect as a specifically quantum-mechanical one. In particular, it can be shown by the mathematical formulation of the theory that the momentum transfer takes place spontaneously. This can be demonstrated experimentally, not by an individual process but, rather, by the measurement of certain integral quantities, as, for example, the Debye-Waller factor.

In conclusion, let me now say a few words on the limits of the methods described. An upper limit for the usable natural line widths has certainly been given when the widths approach the width of the vibrational spectrum of the crystal oscillators.

In this particular case it becomes impossible to distinguish clearly between nuclear processes which are simultaneously accompanied by oscillator transitions and those which are not. However, this would require nuclear lifetimes of less than 10^{-13} second, which do not occur in the nuclear levels available for this type of experiment. Therefore this upper limit is both uninteresting and unrealistic.

More difficult is the question of a lower limit for the available line widths. To go beyond the limit so far attained of about 10^8 eV for the natural line widths is quite possible in principle. There are, however, a number of factors which have delayed extension of the method into the region of higher sensitivity. On the one hand, there are very few nuclei of stable isotopes whose first excited states possess the desired lifetime of greater than 10^7 second. On the other hand, all the previously mentioned side effects of such sharp lines play a dominant role; small disturbances of the crystal symmetry and small contaminations quickly lead to individual shifts in the nuclear states, and these shifts, as a group, produce a very considerable broadening of the extremely sharp lines. In this way the resonance condition is so far violated that the lines are not observed. However, there is a well-founded view that still more sharply defined nuclear transitions will be available before long.

These should lead to multiplication of the possibilities for applying the method of recoilless absorption. We may therefore hope that this young branch of physics stands only at its threshold, and that it will be developed in the future, not only to extend the application of existing knowledge but to make possible new advances in the exciting world of unknown phenomena and effects.

1. W. Kuhn, *Phil. Mag.*, 8 (1929) 625.
2. P. B. Moon, *Proc. Phys. Soc. (London)*, 64 (1951) 76.
3. R. L. Mössbauer, *Z. Physik*, 151 (1958) 124.
4. K. G. Malmfors, *Arkiv Fysik*, 6 (1953) 49.
5. W. E. Lamb, Jr., *Phys. Rev.*, 55 (1939) 190.
6. R. L. Mössbauer, *Naturwiss.*, 45 (1958) 538; *Z. Naturforsch.*, 14a (1959) 211.
7. R. V. Pound and G. A. Rebka, Jr., *Phys. Rev. Letters*, 4 (1960) 337. A complete bibliography of all pertinent researches is included in H. Frauenfelder, *The Mössbauer Effect*, to be published in the series *Frontiers in Physics*, Benjamin, New York.